

May 2024



Established February 1964

BUZZER BOX

Official Publication of the Model T Ford Club of Australia Inc.
Celebrating 60years.



Jake Bonnici
1923 Model T Ute

ONLY ONE PLACE FOR MODEL T & A FORD PARTS



40
YEARS
EXPERIENCE

ORDERS
SHIPPED
DAILY

RESTORATION & HOT ROD PROJECTS

FOR YOUR
MODEL T & A

SERVICING
TUNING
UPHOLSTERY
ELECTRICAL
MAINTENANCE
LIGHT FABRICATION
EXHAUSTS & PARTS

HENRYSPARES.COM.AU

03 5368 1088



PO BOX 91, MARDEN SA 5070
www.modeltfordclubaustralia.org.au



CLUB PATRON: Tony Williams 0432 843 528

PRESIDENT: Adam Jones 0430 118 446 president@modeltfordclubaustralia.org.au

VICE PRESIDENT: Bob Yates 0448 865 967

SECRETARY: Maxine Martin 0400 660 654 secretary@modeltfordclubaustralia.org.au

TREASURER: Kingsley Taylor 0404 373 740 treasurer@modeltfordclubaustralia.org.au

COMMITTEE: Mik Bojko 0438 814 810 Albert Jones 0421 421 388
John Eastick 0412 826 957 Paul Van Ruth 0405 153 968
David Carver 0427 754 250 Matthew Edwards 0437 689 530

MINUTE SECRETARIES: Vacant (Committee Meetings)
John Eastick (General Meetings) 0412 826 957

EDITOR: Committee

CLUBROOM BOOKING COORDINATOR: Bob Yates 0448 865 967

SUPPER COORDINATOR: Doretta Hills 0409 284 861

EVENTS & RUNS COORDINATOR: Adam Jones 0430 118 446

FEDERATION REPRESENTATIVE : Rod Crawford 0429 601 001

FUNDRAISING OFFICER: Doretta Hills 0412 718 862

LIBRARIAN: Neil Hofmeyer 0448 944 756

PROPERTY & PROJECT MANAGER: John Eastick 0412 826 957

MAINTENANCE: Albert Jones 0421 421 388

PUBLIC OFFICER: Mik Bojko 0438 814 810

PUBLICITY OFFICER: Ian Oates 0429 001 910

AUTHORISED PERSONS: Mik Bojko 0438 814 810 David Dunn 0403 582 241
Adam Jones 0430 118 446 Bob Yates 0448 865 967

VEHICLE DATING: Allan Bennett 0403 003 900 David Carver 0427 754 250

PRESIDENT'S REPORT



Hello fellow Model T Ford Club members.

Over the past few days, I along with 40 other club members have visited places that we may not have ever seen, we have traveled on the Pichi Richi, visited historic buildings, stayed in picturesque accommodations, gone through the tunnel of time, and learnt the history of the arid lands. But most of all, we have enjoyed each other's company whilst doing what we love to do most - drive our Model Ts I travelled a total of 482.4 Miles (776.4Kms) I am happy to report that Dolly the Dodge performed absolutely faultlessly. The only small issue I had was the speedo died but I have already managed to fix that as it was only the needle that had come loose.

I am writing this report having just put the Dodge away in the shed. Wow what a week it was, I won't go into too much detail here about the run as I'm sure there will be much chatter at the next general meeting and many reports in future editions of the buzzer box from several members who like me enjoyed our trip and can't wait for the 2025 Annual Run.



On the shed front. It is finally finished, and everything is in its place. It's nice to be able to go out there in the evenings and work on the cars/engines. Don't forget our registration day is coming up on the 19th of May at Fawk reserve. This is an excellent opportunity to pay your membership fees and have your logbooks stamped by one of our Historic registrars. I can't stress enough how extremely important it is for you to have your logbooks stamped every financial year, so as you can continue to enjoy conditional registration. Come along spend a bit of time with fellow club members enjoy a chat and a free BBQ.

Please also note the AGM of our club will be held on the 3rd July, It is now time to consider your involvement in our great club, we need you assistance to make sure this club continues to move forward to its 70th Anniversary and beyond.

If you have any ideas for an interesting run for 2025, please let me know so I can add you to the calendar. With the assistance of many club members, we now have a full calendar of events for 2024, but we need YOU to put YOUR hand up to organise runs for next year. Many hands make lite work. If you don't wish to organise the run but have a venue you would like to visit, no problem pass on your ideas and I will assist in the organisation of your run. Anyway, enough babbling on from me and I look forward in seeing you all on Wednesday the 1st of May at 7pm for the general meeting.

Adam Jones



Life Membership

Is there a member of your club that you think is worthy of this prestigious award.

If so..

The committee welcomes your nomination.

Nominations must be in writing, with a nominator and a seconder, and forwarded to the Secretary

Please refer to the constitution & bylaws for the criteria.

On the Cover

Jake's Green T

Since growing up, I have always loved cars. Watching Bathurst and cheering on Brocky was a highlight of my year so to think that I now own a Ford, its pretty much unheard of.

So, the story goes a little like this.....In February 2020, I purchased my first Model T, the green machine. Being a little apprehensive about owning a Ford was an understatement but moving across to the blue oval and having Trevor and Maxine as my neighbors, I was able to convince myself that that if ever I needed a mechanic, spare parts or good advice, I didn't have to go too far.

I recall being at a car show checking out an old Chevrolet pickup truck on display and then logging on to Facebook searching marketplace. As fate would have it, a Model T Ute popped up on my feeds. Even better was the fact that it was located in Birdwood and the seller was asking a reasonable \$12k.

After inspecting the car, we tried to crank it but we were unsuccessful. I had a good chat with Donald Friend, the custodian of the car and he provided me with some of the history of this historic vehicle.

Donald was selling the vehicle for his older sister who unfortunately couldn't sell it on the Perth market. The car was last registered in Perth and restored by its previous owners Shirley and Graham Anderson. Graham had bought the car in 2009 for \$22,000 – a moment of weakness and a good retirement bank account were to blame for his purchase.



Later that night and after discussions with Trevor, we thought a reasonable offer would be \$7,000 - as it needed some work. After a couple of agonising days, Donald agreed to \$7,500 as he didn't want to return to Perth lugging the car back across the Nullarbor.

Since then, its been happy days. We fixed the started motor (a bent shaft), the e-timer and added a front damper. Took it to Regency, taught the inspectors a couple of things and then decided it was going to be a 1923 Model T Ute (1920 chassis and 1925 engine).

The Ute is still going strong, the most reliable car I own without a doubt. The family love it and it is such a great car to appreciate. The plans aren't big at all - actually, there are no plans, we will just keep driving it until something breaks, fix it and then wait another 100 years. If anything, the Model T has taught me one valuable thing in life - do not drink and drive! I still cant believe there is a pedal for reverse.

My next T, and yes, there will be more will hopefully be a bit bigger. Fitting 3 men on the front bench seat was a little tight but the air conditioning worked quite well.

Its been an absolute pleasure being part of the Model T Club, sharing in the love, knowledge and experience you all have for these unbelievable automobile.

See you all soon.

Jake Bonnici



A taste of what we all got up to on the 2024 Annual Run

(Full story next edition)

Saturday 13th April 2024

It was a reasonably cold morning as we all congregated outside our motel rooms for the short walk to the train station. There was lots of chitter chatter I think most of us were excited at the adventure that lay ahead of us. We had 49 members and friends all booked on to the Afghan Express.

Adam had warned us all NOT to be late as the train waits for no one! At the station a band was having a practice session for us to listen to, some of us couldn't resist a dance.

The train was magnificently restored by a group of volunteers who seem extremely passionate about their trains and carriages. We had a conductor on the carriage who was extremely informative.

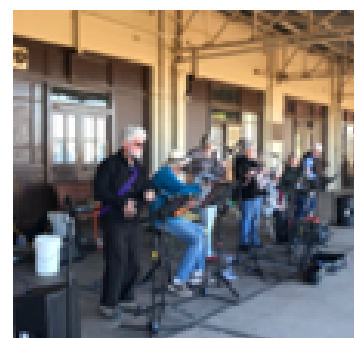

The Flinders Ranges landscape was breath taking as we wound our way through, travelling the old *Ghan* route from Port Augusta, the ranges seemed to creep closer before we entered the Pichi Richi Pass, the hilly scenery was just beautiful.

The Afghan Express is the name railwaymen gave to the passenger train that ran from Terowie to Oodnadatta, through Quorn, in 1923, and was later abbreviated to the *Ghan*.

We stopped in Quorn for lunch, with its quirky little coffee shops, it wasn't hard to find somewhere to enjoy a bite to eat and a much-needed cup of coffee.

Now that we have all been recharged it was time to reboard the train and head back to our accommodation. Some of the younger members had a snooze on the return trip whilst others hung their heads out the window, just for fun! How fabulous to share this day with such a wonderful group of people. This experience evokes so many nostalgic emotions. The scenery was beautiful. I think it will be hard to top this day – you will have to wait for the next edition of the buzzerbox to see what else we got up to as we toured around in our Model T's

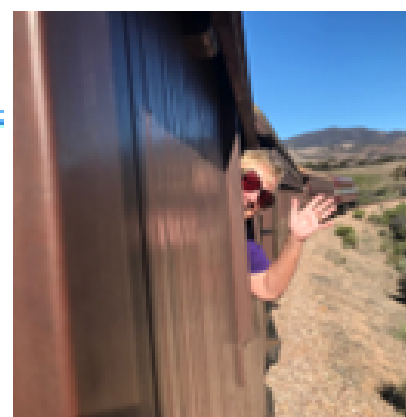

Looking Forward-----Looking Back

60th Anniversary Run,

1030km from my home to Port Augusta via the scenic route & return. 10 vintage cars. A bloody long week.

1st Annual Run

130 km from Greenhill Rd to Murray Bridge & return. A bloody long weekend.

How times have changed.

In 1964 the first Annual Run had about 16 T's in various stages of repair. Some were restored, partially restored or "as found" condition.

We were all intrepid traveler's, hoping to make it all the way to Murray Bridge without a mishap. I made it to Devil's Elbow when I blew a welch plug & had to do a running repair.

Do you remember that a halfpenny is almost the size of a welch plug and with a bit of rubbing the corners with a file or the bitumen road, the halfpenny will fit? Sometimes a bit of persuasion is needed! We all carried a hammer. Run bearings was a regular complaint in the early days & we have all had our share.

Present Day

We all assembled at Crispy Cremes at Bolivar to start a week of driving but instead of a mixture of patched vehicles, we started off with 10 vintage cars, all meticulously maintained. It was a pleasure to sit back with Tail End Charmain and enjoy the site of these vehicles, all around 100 years old, traversing the long haul between the towns.

A couple of mechanical hiccups but all overcome. Jaffa unfortunately had to be trailered after a wheel collapsed. No damage to the car or occupants.

It is a credit to the organizers for this 8-day jaunt. All boxes were ticked & the few small problems were overcome as we went.

Clare, Port Augusta, Peterborough, Burra were our primary stops but most of us stopped into the smaller towns for a look or a coffee. Sally stopped at EVERY town for a coffee.



Our accommodation varied from palatial to ordinary. The Steam Museum & Light show were spectacular, Arid Lands tour was great, Pichi Richi Rail Tour was another bucket list event, now ticked off.

I'm in the ~~sh*t~~ for my purchase at the Art Gallery, but Oceana Electric now sits in our lounge room much to Lyn's disgust.

FOOD. We ate and gained about 5 Kilos this trip. 40 people trooping into a venue & always getting a great meal. Again, a lot of planning was required to sort us out in a timely manner.

Thanks to the organizers, it was great to catch up with all our friends.

John & Lyn Scorgie.

More stories to come next edition.

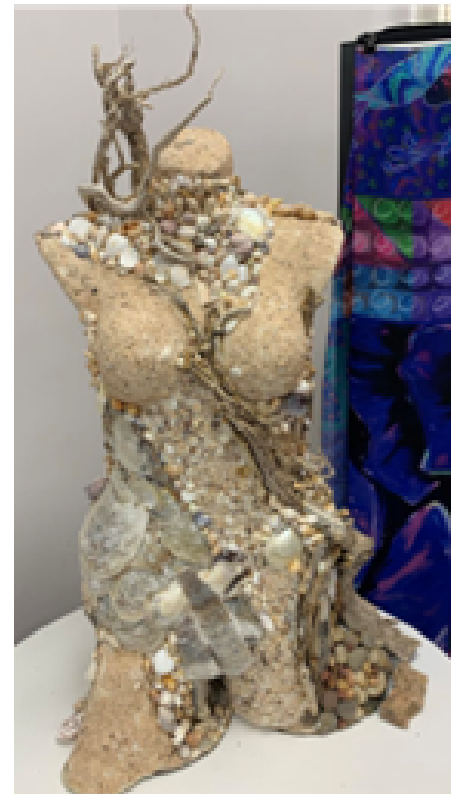

Mid Year Dinner

Saturday 15th June 2024

7.00pm

**Tower Hotel
621 Magill Rd,
Magill**

Bookings essential by 7th June

secretary@modeltfordclubaustralia.org.au

0400 660 654





IN HIS OWN WORDS

I'm not sure where to begin, writing this article for this month's Buzzer Box, but I shall do my best from what I can recall going back some 40 years to 1982 when my association with the Model T Ford Club.

My adventure started with being involved in Ballroom Dancing. This is where I met up with David Dunn when attending one of the yearly Post Office Balls that was held at Centennial Hall at the Wayville Showgrounds (now demolished). This was a great time for me to be able to catch up with other dancers I have known over the years, who were associated with Dancing Clubs in this state.

Somehow, I got involved in a conversation with David about cars, and the subject of the Model T car came up as David was a current owner. From there, I was extended an invitation to go around to Gordy's (David's Father) place one Saturday morning, to see what activities took place there.

It was very interesting for me to see Gordy working away on a Model T and to see what he had achieved regarding restorations, including maintenance aspects, on the vehicles he had housed at his place. Gordy was more than happy to work on them, but he was not at all interested in having to drive one at that time. His attitude did eventually change, many years later. I particularly enjoyed the times we spent together to have a cup of tea whenever time permitted at the back porch end of the house.

From there on, I tended to go around to Gordy's more frequently. On one occasion Peter Dunn turned up, and he and David were discussing something about the "All Ford Day" which was being held at the Gawler Showgrounds later that year. I wasn't paying much attention to the conversation that was going on until Peter approached me saying that he was interested in taking John Lasscock's Truck out on this run, but because he had his own car that this was not at all possible.

Peter finally asked me if I would be interested in driving his car on the "All Ford Day" event which would allow him to approach John regarding driving his Truck. I informed him that I had never even driven a Model T Ford. He said that this wouldn't be a problem (that's all right for him) but, if I was to accept, he was prepared to teach me over the next couple of weekends prior to the run to get the feel of it.

I accepted Peter's invitation, and as far as I can recall, I had two lessons, totaling approximately an hour and a half in all, to master the vehicle. Peter felt confident enough after my ordeal and permitted me to take his car on this day. I did have one mishap on the day and that was when, leaving the Gawler Oval, I stalled the car because someone cut out in front of me. It was a bit scary, but all was well, so I then proceeded to travel home. Whilst driving home I felt so thrilled to be driving a Model T, and it was then that I became so enthusiastic that I decided to join up and become a member of the Model T Ford Club.

It was quite an experience to drive for the first time. Total concentration was required whilst driving, but it was all worth it, as I was hooked! I enjoyed the general meetings that were held at Main Street, Eastwood, the interaction with members, seeing some of the ladies knitting jumpers etc, and a cuppa tea or coffee at the end of the evening made it all feel very homely, and of course the Sunday club swap meets.

Having now been involved with the car club for some time' I felt that the time was right for me to go searching around and find a vehicle of my own. Mainly thanks to David Dunn's research, we were able to locate a Ford TT 1 Ton Truck at Tusmore. I purchased that truck in late 1982. David was kind enough to trailer it home for me, and, with his help and general knowledge, we started working together on the restoration project of this truck. Things progressed quite slowly, having to sort out and order replacement parts, and then the long delay with shipment timetables waiting for components to arrive.

In the meantime, I often went on club excursions with John Lasscock, not having a vehicle of my own. John would generally drive around everywhere in his 1927 Coupe, which had a Reeder Head (if I am correct) making it a very smooth car to drive and it provided a little extra power. He was a very generous man in allowing me and other members of our car club to drive his cars on several occasions, whenever there was a club event on. The late Margaret Leonard was our permit officer back then, and she would arrange for a three-day vehicle permit for all of the cars that were participating on the club run. John would advise you in advance which car he had allocated to you for a given run.



I can remember one occasion, when I was allocated the Cadillac to drive. I decided to take my parents on this a short picnic run to Reynella. It was a lovely cool day, ideal for a running board lunch. As John had provided me with this car for the run, it had to be taken back to his home at Lockleys at the end of the day. Due to his generosity, I decided to go to the Airport to refill the fuel tank, but when the bowser indicated that I had booked up \$30.00, I thought that this was enough and left it at that.

At the next General meeting of the club, John approached me and asked if I had placed any petrol in the car, and I said yes, in appreciation for allowing me to drive it. He stated that I shouldn't have, as it was his domain to ensure the cars had sufficient fuel. John was a very generous person. He was always called Mr. Mintie, as he would always hand out these lollies to children, wherever he pulled up on a run, this was definitely a draw card for children, which was lovely.

During 1983, John's daughter Katie got married and all the cars John owned were allocated to her as a Wedding present, apart from the Nursery Van which was to stay. Katie had decided that she didn't want the cars and would prefer a cash payment in lieu. John then reluctantly sold off several vehicles to members of our club, as he did not want any of them to head off by going interstate.

Later that year, when John approached me, I acquired my 1922 Ford T Tourer, which is now my pride and joy. It was the beginning of my long-time involvement with the club where I have established many long-term friends over the years.

by Stuart Bowshall

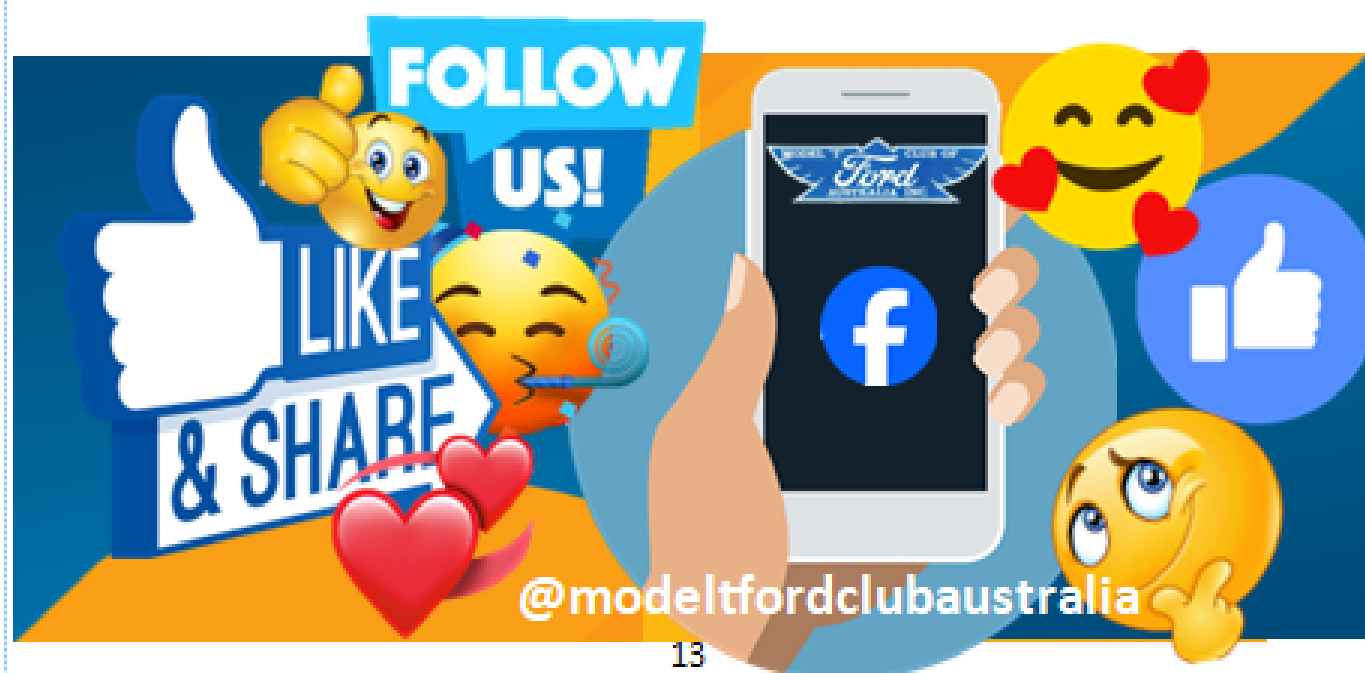

**FAWK RESERVE
HALL**

**SUNDAY 19th MAY
10.30am - 2.30pm**



Registration Day

LOGBOOK RENEWALS

REPLACEMENT LOGBOOKS \$5.00

Membership Renewal Fees

FULL

\$55 p.a.

CONCESSION

\$50 p.a.

Associate

\$60 p.a.



**BBQ
LUNCH PROVIDED**



Membership fees are due and payable by 1st July

Please note that under the current conditional registration scheme if you are not a financial member of a club your car is NOT registered and you can not legally drive on the road.

Upcoming Events

DATE	ORGANISER	EVENT	LOCATION	START TIME
Wednesday 24th April	MTFCA	Buzzerbox Committee Meeting	Fawk Reserve Hall	17.00pm 18.15pm
Wednesday 1st May	MTFCA	General Meeting	Fawk Reserve Hall	19.00pm
Sunday 19th May	MTFCA	Registration Day Free BBQ	Fawk Reserve Hall	10.30am - 14.30pm
Wednesday 29th May	MTFCA	Buzzerbox Committee Meeting	Fawk Reserve Hall	17.00pm 18.15pm
Wednesday 5th June	MTFCA	General Meeting	Fawk Reserve Hall	19.00pm
Saturday 15th June	Maxine 0400 660 654	Mid Year Dinner	Tower Hotel 621 Magill Rd. Magill	19.00pm
Wednesday 24th June	MTFCA	General Meeting	Fawk Reserve Hall	19.00pm
Wednesday 3rd July	MTFCA	Buzzerbox Committee Meeting	Fawk Reserve Hall	17.00pm 18.15pm
Sunday 21st July	David Carver 0427 754 250			

Please consider your involvement in OUR CLUB



Notice is hereby given
of the
Annual General Meeting
Model 'T' Ford Club of Australia
to commence at the conclusion
of the General Meeting



The Model T Ford Club of Australia
needs members to become office
bearers or to join our Committee of
Management for the year 2024/25.

Members can nominate themselves
or another member (with their
permission)

Please refer to page 3 of the Buzzerbox
for full a list of Office Bearers

AGENDA

Wednesday
3rd July
2024

Vale
Acceptance of previous
minutes
Presidents Report
Secretary's Report
Treasurers Report
All positions declared vacant
Incoming Presidents Report
Honours & Awards
Life Membership
Clubman of the Year
Lizzy Lady
Restoration of the year
General Business

Supper will be served
at the
conclusion of the
meeting



John Lasscock was such a gentle-
man, he would always remember
the mothers from within the club
and present them with flowers for
Mothers Day at the May General
Meeting.



Apple and Sultana Slice

Preparation : 35 mins plus 2 hours to chill

Cooking : 50 mins

¾ cup plain flour

1 cup castor sugar

125 gm chopped cold butter

125 gm extra , melted.

*1/3 cup flaked almonds
chopped*

6 red apples , peeled, cored and

½ teaspoon ground cinnamon

½ cup sultanas

1 ¼ cups self-raising flour

¼ cup desiccated coconut

Preheat oven to 180C. Grease and line 30x20cm slice pan with baking paper extending at long sides for handles. Combine plain flour and ½ cup of the sugar in a medium bowl and using fingertips, rub in chopped butter to form coarse crumbs. Add almonds and mix to combine. Set aside.

Combine apple, 2 tablespoons of remaining sugar, cinnamon and sultanas in a saucepan over moderate heat. Cook covered, stir occasionally for 5-6 mins until apple softens. Remove from heat and stand covered for 10 mins.

Combine SR flour, remaining sugar and coconut in a bowl. Add melted butter and stir to form a crumbly dough. Press dough evenly over base of prepared pan, smooth surface. Spoon the apple over the base. Sprinkle almond mixture evenly over the apples.

Bake for 40 mins or until golden brown. Remove from oven and cool to room temperature. Chill for 2 hours. Serve cut into pieces.

Notes :

Can use raisins, currants or dried cranberries instead of sultanas.

Delicious served with icecream, cream or custard.

MINUTES OF GENERAL MEETING HELD

3rd April 2024

1. WELCOME:

- 1.1. Meeting commenced at 7.02pm with the attention of members being gained by use of a car horn provided by Ian Oates.
- 1.2. The President welcomed everyone to this meeting, reminded members to sign the Attendance Record Book and advised that this meeting will be audio recorded for minute taking purposes and the recording will be deleted once the minutes have been accepted; There are a number of rally hats from Allan Bennett that are available for members in exchange for a donation to the Club; There was a train driver's hat from Allan Bennett for anyone to wear on the Pichi Richi Railway trip on the 60th Anniversary Run; There is an army slouch hat from John Clarke on the front table to remind us of being the month of celebrating Anzac Day; A happy birthday for today was extended to Adrian Probert (present) and applauded.
- 1.3. Members Tony and Lindsay Nash of Jerusalem (Kadina, SA) arrived late and just ahead of the New Membership item below and were applauded.
- 1.4. Visitors: Nil.

2. APOLOGIES:

- 2.1. Tony Williams, Mik Bojko and Matthew Edwards.

3. MYSTERY OBJECTS:

- 3.1. Nil.

4. FUNDRAISING:

- 4.1. Doretta Hills initiated a raffle of seven prizes.
- 4.2. The President reminded everyone that the proceeds go to Operation K9 and he encouraged members to buy up tickets.

5. MINUTES OF LAST GENERAL MEETING, 6TH MARCH 2024:

- 5.1. As distributed in the April 2024 edition of Buzzer Box.

Moved: Allan Bennett, that the minutes be accepted; Seconded: Paul Van Ruth; Carried.

6. BUSINESS ARISING FROM THE MINUTES OF THE LAST GENERAL MEETING:

- 6.1. Exhaust pipes: Allan Bennett spoke of his research into prices and availability – for mild steel pipes, \$99.50 each for five and \$77.55 each for ten; for stainless steel pipes, \$108.35 each for five and \$86 each for ten; David Carver validated the prices against those that he had researched from Snyders (that need to include freight); The Committee will discuss the matter at its next meeting; Current interest is two via Allan Bennett and one for Rod Crawford.

7. PRESIDENT'S REPORT:

- 7.1. The President advised: A reminder that 2024/25 membership fees will remain the same as 2023/24, being \$50.00 Concession, \$55.00 Full and \$60.00 Associate; Model T Ford National Rally in 2027: Our Club is the host state and a subcommittee needs to be formed – a meeting of interested persons will be convened on Tuesday 7 May 2024 at the home of the Secretary. Please email the Secretary if you would like to assist in the organisation of this Rally; Life Membership: Nominations are now open and if you would like a copy of the criteria, please email the Secretary. If there is someone in the Club that you feel is a worthy recipient, please email the Secretary. The nomination must have both a nominator and a seconder and the case for award against the criteria.

Moved: David Carver, that the President's Report be accepted; Seconded: Bob Yates; Carried.

8. SECRETARY'S REPORT:

- 8.1. The Secretary reported Correspondence In: The usual club magazines were received and forwarded/provided to Neil Hofmeyer for inclusion in the library; Email about the last leg of

the Model T World Tour – tomorrow, Dirk and Trudy and their support team will be flying from Amsterdam to Beijing, pick up their cars from the port of Xingang and then travel 20,000 kilometres through Asia and back to Holland. You can follow their adventure at www.modeltworldtour.com or go to a link on the Club's Facebook page.

- 8.2. The Secretary reported Correspondence Out: Email to all Hiring Clubs with photos of the progress on the new Clubrooms; Email to all Annual Run attendees with a reminder of the starting point, a reminder of memorabilia purchases and that there is no Tail End Charlie.
 - 8.3. Website: The Secretary asked members to log into the Club's website and the Committee welcomes any constructive feedback via the Secretary; A link to the new Code of Practice is on the site.
 - 8.4. Facebook: The Secretary advised that the Club's Facebook page is fully operational.
- Moved: Rod Hills, that the Secretary's Report be accepted; Seconded: Merry Perry; Carried.

9. NEW MEMBERSHIP:

- 9.1. Associate Membership application received – Andrew Daff of Woodville South with his 1990 Nissan Pulsar; It was explained that his car was special having belonged to his Mum and one of our members encouraged Andrew to join our club.

Moved: Adam Jones, that the membership for Andrew be accepted; Carried.

The President welcomed Andrew to the Club.

10. BUZZER BOX REPORT:

- 10.1. The Secretary reported: Thanks to all contributors of the April 2024 edition; May 2024 edition contributions are now being sought by mid-March 2024; spare copies are on the front table.
- 10.2. Paul Van Ruth spoke of the articles he had arranged: 'Cover Stories' in the balance of 2024 editions as follows: May – Jake Bonnici, June – Annual Run; July – Ian Russell August – Allan Bennett, September – non-member Mike Keogh, October to December inclusive – **volunteers needed please**; 'In Their Own Words' stories in the balance of 2024 editions as follows: May for 1977 to 1982 – Stuart Bowshall, June for 1983 to 1988 – Brian Teakle, July for 1989 to 1994 – Bob Yates, August for 1995 to 2000 – Merry & Peter Perry, September for 2001 to 2006 – **volunteer needed please**, October for 2007 to 2012 – Paul & Sue Van Ruth, November for 2013 to 2018 – John Clarke and December for 2019 to 2024 – Shane Murray.
- 10.3. The Secretary advised that short stories received for any year of the Club's history can be inserted in any edition as space permits.
- 10.4. Postage: A discussion took place about the additional postage costs from \$1.20 to \$1.50 each time an edition is posted; the options going forward for a member currently receiving hard copy are: email in lieu of hardcopy OR collect from Clubrooms at the next meeting OR mail on the basis of payment of a levy to cover the additional postage cost; The options will be included on the 2024/25 Membership Application form and is to be paid as an additional cost at the time of paying membership fees.

Moved: Adam Jones, that members who want hard copy of the Buzzer Box sent in the mail be levied \$5 per year commencing from 1 July 2024 to recover the extra over postage cost that the Club will incur; Seconded: Rod Hills; Carried.

11. TREASURER'S REPORT:

- 11.1. Kingsley Taylor outlined the reconciliation of accounts for the month of March 2024; a reconciliation is available for viewing after the meeting; The closing balance has increased significantly because of all of the member payments received and being held for the 60th Birthday Annual Tour.

Moved: Allan Bennett, that the Treasurer's Report be accepted; Seconded: Trevor Martin; Carried.

12. PROJECT MANAGER'S REPORT:

- 12.1. The building plans and specification documentation was on the front table for anyone's viewing.
- 12.2. John Eastick updated members on progress since the last General Meeting and article in the April 2024 edition of Buzzer Box: Progress has continued to be very good; As of this evening, the building has been completely wrapped with sisalation ready for cladding, windows frames, hoods and shrouds have been installed, air conditioning ductwork has been installed with some electrical work has commenced; There has been no advice of the success or otherwise of the Club's application for the SACCP; In response to Allan Bennett's query at the last meeting, the Council has confirmed that an EV charging station will not be included in this project.
- 12.3. The Secretary advised that some site photos taken last Thursday were uploaded on the Club's Facebook page.

13. PROPERTY OFFICERS REPORT:

- 13.1. No report provided.

14. CLUBROOMS MAINTENANCE COORDINATOR REPORT:

- 14.1. Albert Jones advised that there will be a Working Bee planned for a date after the 60th Anniversary Run.

15. CLUBROOMS BOOKING COORDINATOR REPORT:

- 15.1. Bob Yates had nothing to report.
- 15.2. The Secretary advised that a schedule of home games is awaited from the West Croydon Football Club so as to check any conflicts with booked activities by various Hiring Clubs and our own Registration Day in May 2024.

16. FEDERATION REPRESENTATIVE'S REPORT:

- 16.1. Rod Crawford reported: The next Federation meeting is being held on Saturday, 6 April 2024.

17. EVENTS AND RUNS COORDINATOR'S REPORT:

- 17.1. Adam Jones advised that the Club has a full calendar of organised Events and Runs in 2024.
- 17.2.

18. PAST EVENTS:

- 18.1. *St Patrick's Day Run* on Sunday, 17 March 2024: Organisers: Maxine Martin and Rod Crawford; In a change of plans, the destination was the Historic Motor Vehicles Gathering at Barrett Reserve at West Beach; Allan Bennett reported that it was a good day with hot weather but breezy under the trees for relief; Paul Van Ruth reported that it was a pleasant day out, the event was well organised, there were good and interesting food options and he won a family pass to the Railway Museum in Port Adelaide for voting in the favourite vehicle competition; The Gathering was moved out of the usual Anzac Highway location because it has been designated as a campsite for homeless persons; Advertising will be improved for next year's event

19. FUTURE EVENTS – CLUB ORGANISED:

- 19.1. *60th Anniversary Annual Tour 2024* to the Port Augusta region between Thursday 11 April and Thursday 18 April 2024: Organisers: Adam Jones and Albert Jones; Now 8 days away; Adam spoke of certain arrangements to follow up earlier email correspondence: Albert and Rosina need to take credit for undertaking most of the planning; The route has been planned via Google Maps; Originally about 12, there are 9 or 10 Model T Fords participating; All bookings confirmed; The defibrillator and first aid kit will be carried on the Tour; Rob Balfour made an enquiry about being a late entrant; There will be no Tail End Charlie and entrants are expected to make their own arrangements for breakdown assist; The Club has memorabilia in the form of embossed

mugs for \$12.50 each and if ordered early enough, can be presented at the Tour; No-one had any further questions at this stage of the Organisers.

- 19.2. *Registration Day* on Sunday, 19 May 2024; Organiser: Committee; Free BBQ lunch
- 19.3. *Mid-Year Dinner* on Saturday 15 June 2024; Organiser: Maxine Martin
- 19.4. *Monthly Run* on Sunday, 21 July 2024; Organiser: David Carver; David is considering the destination as Mt Lofty Botanical Gardens; free entry and picnic lunch
- 19.5. *President's Run* on Sunday, 18 August 2024; Organiser: Adam Jones; Adam is considering ideas
- 19.6. Further club events were not mentioned during this item of the meeting.

20. EVENTS - INVITATION:

- 20.1. Specific events that are advised and/or raised at meetings by members can be listed here.
- 20.2. Otherwise, invitation events are advised to members via the Notice Board and the Website but not in Buzzer Box, whether hard copy or emailed; Members are encouraged to please check the Notice Board when at the Clubrooms.

21. GENERAL BUSINESS:

- 21.1. Birthdays: Rod Hills and Glenyss Trenorden on Friday 5 April – congratulations were extended with applause.
- 21.2. John Clarke spoke of the 1916 Lighthouse vehicle on the front page of the April 2024 edition of Buzzer Box and how it soon will be placed in the Milang Vintage Machinery Club's Museum.
- 21.3. 2025 National Rally in Ballarat, Victoria: David Carver spoke of his phone call from member Rob Balfour seeking information and how little information from the Organisers had been received; Rob was suggesting Club members try and be accommodated in one location; Merry Perry spoke of her enquiries; Neil Hofmeyer spoke of car and trailer parking being an issue at most venues.
- 21.4. Prize pool of seven; The plant pots were painted by Gayl Carver (thank you Gayl); The President congratulated all winners; Doretta Hills reminded everyone that proceed go to Operation K9.

22. MYSTERY OBJECT REVEAL:

- 22.1. Nil.

23. RAFFLE DRAW:

- 23.1. Prize pool of seven; The plant pots were painted by Gayl Carver (thank you Gayl); The President congratulated all winners; Doretta Hills reminded everyone that proceed go to Operation K9.

24. CLASSIFIEDS:

- 24.1. Ian Oates has an unrestored 1926 motor and 2 x 21 inch wooden wheels for sale.
- 24.2. John Clarke has a ground up, fully restored 1942 Willy's Jeep for sale.
- 24.3. All classifieds to be emailed to Bob Yates who will coordinate future classified advertisements and to be included in Buzzer Box.

25. NEXT MEETINGS:

- 25.1. Buzzer Box Night: Wednesday, 24 April 2024 from 5.00pm at the Clubrooms.
- 25.2. Committee Meeting: Wednesday, 24 April 2024 at 6.15pm at the Clubrooms.
- 25.3. General Meeting: Wednesday, 1 May 2024 at 7.00pm at the Clubrooms.

26. MEETING CLOSURE:

- 26.1. The President reminded everyone to sign the Attendance Record Book and of the rally hats in exchange for a donation to the Club.
- 26.2. The President invited those present to have a chat and enjoy supper.
- 26.3. Meeting was closed at 7.58pm.

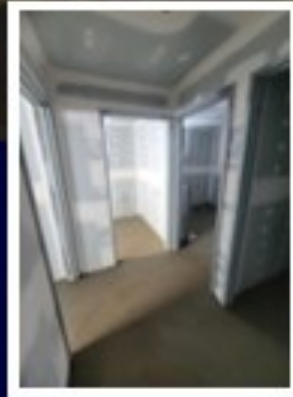

OUR DREAM CLUBROOMS

— PORT RD. CROYDON —

Contractor Mykra has continued to make excellent progress since the roof was installed.

The internal activity has included 1st fix services (being for plumbing, electrical, solar, security, audio/visual and air conditioning), door frames and architraves, walls and ceilings, wet area floor screeding and some painting.

External activity has included wall cladding, roof vents and preparation for concrete and block paving. With fitment of the external doors, lock up has been achieved.

By the time you read this article, wet area tiling, painting and paving will be well underway, and some possibly completed. The scope of landscaping is still being finalised.

Progress photos are still encouraged please. If visiting the area or just passing by and observing anything which raises your attention or is noteworthy, please let me know, thank you.

Further information is included in the Club's Project Manager's Report referenced in the minutes of the April 2024 General Meeting and included in this edition of the Buzzer Box.

If you have any queries or are seeking clarification about the project, please don't hesitate to contact me.

John Eastick

Do you receive your buzzerbox via Post?



As you would be aware Australia post has significantly increased the price of postage, therefore the committee has made the decision that with no increase to membership fees for 2024/25 we will need to pass this increase on to our members that receive their Buzzerbox in the mail.

A \$5.00 surcharge per year will be passed on to those members wishing to receive a copy in the mail.

Please indicate your wishes to continue to receive a hard copy by ticking the box on your membership renewal form and making payment to the treasurer along with your membership fees, no latter than the 1st July, You will continue to receive you buzzerbox by email or if you so choose you can pick up a hard copy at either the General or committee meetings.

“The best and most beautiful things in the world cannot be seen or even heard, but must be felt with the heart “ - Helen Keller

SUNDAY Morning 'CARS & COFFEE' Themed Events

DATE	EVENT NAME + Facebook Name/Page Link	SUBURB / TOWN (South Australia)	TIME
1 st SUNDAY	Cars & Coffee Blackwood	BLACKWOOD – 386 Shepherds Hill Road	0700-0900
	Coffee & Classics	GEPPS CROSS Home HQ – Main North Rd, Gepps Cross	0730-0930
	Coffee n Cars in the Vale	McLAREN VALE – 130 Main Road	0800-1030
	Cars & Coffee Murray Bridge	MURRAY BRIDGE – Wharf Precinct Car Park, Clark St.	0800-1000
	Cars & Coffee Barossa	NURIJOTPA – Bean Addiction, 18-28 Tanunda Road	0800-1030
	Hot Rod Haven (Hot Rods & pre-65 customs)	WEST BEACH – Henley Sailing Club, 1 Seaview Road	0800-1030
2 nd SUNDAY	Coffee Classics & Chrome	ABERFOYLE PARK – Village Shopping Ctr, 142 Hub Drive	0800-0930
	Coffee & Cars Riverland	BERRI – Senior Citizens Carpark, 9/12 Crawford Terrace	0900-1100
	Northside Coffee & Classics	GOLDEN GROVE – The Grove Shopping Ctr, The Golden Way	0800-1030
	Cars And Coffee Hahndorf	HAHNDORF – Fruit & Veg Market, 182 Mt Barker Road	from 0800
	Cars and Coffee Largs Bay (NEW)	LARGS BAY – Sailmaster Tavern, Arcadia Ct, North Haven	0700-0900
	Cars & Coffee Mt Barker	MT BARKER – Homemaker Ctr / Laratinga Café, 6 Dutton Rd	from 0800
	Cars on the Coast	PORT NOARLUNGA – Beck's Bakehouse	0800-1030
	Victor Harbor Cars & Coffee	VICTOR HARBOR – Foreshore Carpark opposite 3 Esplanade	0800-1030
3 rd SUNDAY	Super Sunday Get Together	ANGLE VALE – Shopping Centre, 121-129 Heaslip Road	0800-1100
	Breakfast with the Devils	GREEN FIELDS – Whiteline Transport, 1 Belfree Drive	0800-1000
	Chrome in the Valley	HAPPY VALLEY – Shopping Centre, 50 Kenihans Road	0800-1000
	Compass Cars n Coffee	MT COMPASS – Main Street, BP Service Station	0800-1000
	Cars and Coffee Tonsley	TONSLEY – MAB Circuit, Tonsley	0700-0930
4 th SATURDAY	Coffee N Chrome (Saturday evening)	MILE END SOUTH – Mile End Home, Railway Terrace	1800-2100
4 th SUNDAY	Coffee & Machines (moved from 1 st Sunday)	ABERFOYLE PARK – The Hub Cafe, 5/130-150 Hub Drive	0730-0930
Last SUNDAY	Cars & Coffee on the River at Mannum	MANNUM – Ferry Landing	from 0830
	Port Pirie Cars & Coffee	PORT PIRIE – Domino's Car Park, 10 Main Road	from 1000

NOTE: Check with each event/hosts Facebook page as details can change. All above events are in South Australia.
Compiled by Grant Zippel. Updated: 07/02/2024

TINKERING WITH BOB

MODEL T FORD TINKERING BITS – CONTINUED No 8

TIGHTEN LOOSE SPOKES

In some of the drier areas of the country, or if the hub bolts have been allowed to become loose, the problem of keeping the wood wheel spokes tight can be a problem. The cure or fix that follows is meant to be used on wood wheels where the spokes are structurally sound. The very lives of one's family and friends are dependent on sound wooden components. Should there be any question in your mind about the integrity of your wooden wheel spokes, please do forget any restorative endeavour and have your wheels rebuilt by a professional.

Many members in the local groups through out Australia have been able to make the spokes as tight as they are in new wheels by the following process, The first thing to do is to remove the wheel hub, being careful not to knock out any of the spokes. Then by driving a 2" exhaust pipe expander or similar, may need to be boughed from another member for the process, place same into the hub opening and the spokes will expand outwards.

Cut same sheet metal shims about 1" by $\frac{3}{4}$ " and as thin as possible, they are driven into the crevices opened between the spokes at the hub. In times past one could use metal from a soft drink can before they were made from Aluminium. The practice is to use as many shims as possible driving them in, alternating from one side of the hub to the other. Avoid placing shims between the spokes that have the hub bolts holes if possible.

Usually, five shims will tighten the wheel sufficiently. When the expander is removed the hub can be reinstalled. Before installing the brake drum and the final tightening, make sure that the wheel revolves true and there is no run out.

The Ford service manual advises to once the wheel is all back together to peen over the ends of the hub bolts.

I recommend that you do not do this but acquire a good medium strength Loctite, so as the bolts can be used again if necessary.

NOISY TIMING GEARS

The noise in a T engine is most always eliminated after a rebuild where the crankshaft and Camshaft gears have been replaced. If the pesky noise is still there, it could be that the mesh is bad between the generator drive and the camshaft timing gear.

If this is the case, there is an easy fix. The timing gear cover, PN 3017, shown at the left of the attached diagram below, may be adjusted by placing one or two gaskets, PN3017-C at the point designated by the letter A on the attached diagram where it joins the engine block.

The generator drive pinion and the large timing gear should mesh with a clearance of 0.002' to 0.004" at the point designated by the letter B on the attached diagram.

The proper gasket can be secured from a parts vendor or can be cut from a piece of gasket material also purchased from your local parts store

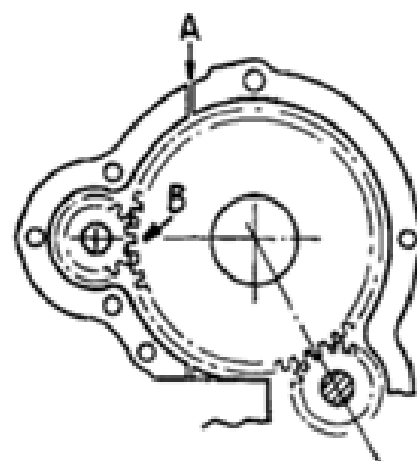

MODEL T FORD OILERS

One of the biggest problems with the model Ts system of oilers on the spring, shackles, spindle bolts and the tie rods is that the oil soon oozes out around the shafts we are trying to lubricate. This of course makes a total mess of your clean front end. We have to replace what has leaked out, which further adds to the mess, for some T owners this is very frustrating. What is required is an oil that will stay put and do what is required to. It has been advocated that the use of a heavier grade, say SAE 250 or similar grade that is available from your local auto spare shop.

For spring perches, it works best on the latter Ts that have the perches fitted with the toilet seat type oilers, as the flow to the bushings is better. We have made mention that this is applicable to the latter Ts, but nothing stops you modifying you earlier T with these oilers.

PHILIP EGEL

CARLEAN LANGBEIN

ROLF SELLRNTIN

ANTHONY TAVERNA

PENELOPY SCHULZ

RODNEY CHAPMAN

BRENTON OATES

MAXINE MARTIN

DARREN CHATFIELD

ROBERT TRUNKS

JOSIE PAINE

IAN SMITH

JOHN EASTICK

IAN DENTON

ADAM JONES

PETER KERR

SALLY NICHOLAS

SAXBY FITZIOHN

HAPPY

Birthday



SCAMMELLS

AUCTIONEERS & APPRAISERS

ESTATES • COLLECTIONS
ART • MOTORING & COLLECTABLES

**Free Appraisals
& Interstate
Delivery Available**

Inspection Times:
Friday 2 - 5pm
Saturday 9am - 12:30pm

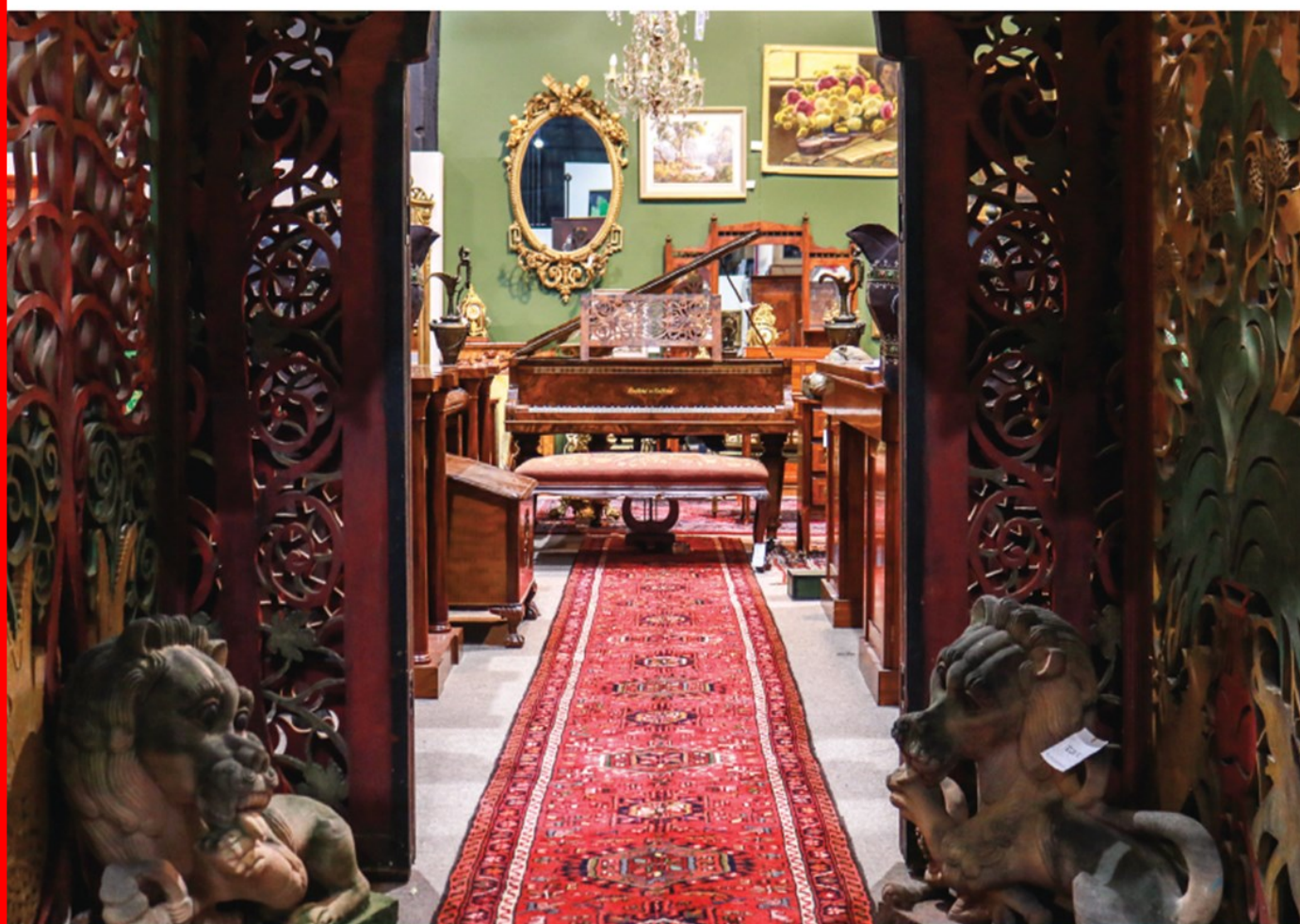

7 Chapel Street, Norwood | 8362 0404 | www.scammellauctions.com.au



SHARE THE PASSION



**“ NO ONE KNOWS YOUR
PASSION LIKE SHANNONS. ”**



Shannons Home and Comprehensive Car and Bike insurance is for motoring enthusiasts just like you, with features like:

- Choice of repairer
- Agreed value
- Multi-Vehicle & Multi-Policy discounts
- Limited Use & Club Plate cover
- Laid up cover
- One excess free windscreen claim per year
- Total loss salvage options
- Home & Contents Insurance including \$10,000 enthusiast items cover for your collectables & tools
- Towing & storage costs as a result of loss or damage
- Pay by the month premiums at no extra cost

Call Shannons on **13 46 46** for a quote on your **special car, daily drive, bike or your home**, and speak with a genuine enthusiast.

Shannons Pty Limited ABN 91 099 692 636 is an authorised representative of AAJ Limited ABN 48 005 297 807, the product issuer. Some benefits only apply to comprehensive vehicle cover. Shannons has not taken account of your objectives, financial situation or needs. Read the Product Disclosure Statement before buying this insurance, available at shannons.com.au. The Target Market Determination is also available. Terms, conditions, limits and exclusions apply. The type of cover must be specified on your certificate of insurance. If you do not use your vehicle in accordance with the vehicle usage shown on your policy certificate you may not be covered in the event of a claim. Discounts do not apply to the optional Shannons Roadside Assist or CTP.



Scan to find out more

**INSURANCE FOR MOTORING ENTHUSIASTS
CALL 13 46 46 FOR A QUOTE | SHANNONS.COM.AU**